

Facts

HD OB Van –up to 5 camera chains
Volkswagen Crafter long version- from 2010
“One room concept”
Ready to produce
31.000 km only - OB looks like new
Price on request!

This OB Van was build for all kind of Sport and Entertainment productions as “Unilateral Van” (Soccer, Basketball, Concerts, etc.) as unilateral Van, as OB and editing Van.
The flexible signal distribution makes all kind of production setups possible.



OB-Van HD : Price on request - ex Austria

Available: Immediately

All is prepared in HD

5 camera chains Panasonic AG-HPX-300 series with lens are included

5x Camlinx systems –full camera control – tally – also for other cameras – see on the list!

Year of build: 2010

Mileage: 31.000 km only

Pre-cabled for up to 6 camera chains – preparation for up to 8 chains possible – on request!

Pre-cabled for 1x EVS, for 1x Recording – EVS is not included in the package – on request!

Facts: HD OB van with 5 HD cameras ready to work

This OB Van is from 2010. It has 31.000 km and looks like new.

Price: On request

VEHICLE

- Volkswagen Crafter Extra long Diesel engine.
- New built ob van, 7,3m length, less than 3500 kg, no 90km/h limit, no Tachograph needed, normal driver licence.
- 2 production seats / 4 working seats.
- Small size Van, fast on the road, arrives at places where big trucks can not come.
- Everything on CEE 32A power.
- Working with 5 cam link HD/SD systems with Panasonic AG-HPX-300 cameras.
- Fibre cable assembly 4x 150 mtr. + 1x 300mtr. meter Hybrid Fiber (SMPTE 311) cable on Lemo connectors.
- 6 camera controls (Panasonic) – upgrade to 8 camera controls possible.
- 4 focus and zoom controllers (Fujinon/Canon)
- 4 HD on-camera monitors

SPECIFICATIONS

Model:	Volkswagen Crafter
Age:	First registration: 2010
Length:	7.3m
Width:	1.7m
Weight:	3400 kg
Voltage:	380/415V
Power Connector:	CEE 32A 5Pin
Engine/Gearbox:	Diesel
Air Conditioning:	roof mount units
Maximum of Cameras:	8(SDI)+2(HDMI)

Maximum of Recording Positions: 10
HD Formats: 720p, 1080i
SD Formats: SD PAL/NTSC

Production:

Vision Mixer – Production: 1x Atem Overture 1 -1 ME – 10 inputs

- 8 SDI(3Gbps HD standard) inputs and 2 Analog/HDMI inputs
- Internal Frame Synchronizers for all inputs
- 2 HD-SDI program outputs, 1 HD-SDI preview output and 3 HDSDI auxiliary output
- 2 Multiformat outputs (CVBS, Y/C, YPbPr and HDMI)
- 4 M/E Keyers
- 2 Downstream Keyers
- 32 Live Image Buffers
- 2D DVE with 3D Borders and Drop Shadow
- 10 Channel Multiviewer (HDMI or DVI display)
- Clip Player with Audio (32 still images and 150 frames with alpha and audio)
- Compix interface to load and play graphic pages

DVE – Production: 1x Atem Onboard

Monitor Lines – Production: 10

Displays Production: 1x LED 47" (LG)
6x LED 22" (LG)

Multiviewers/Splitters Production: Atem Onboard (Echolab)

Vision control:

Cameras: 5x AG-HPX-300 series (Panasonic)

Lenses: 4x Fujinon XT17x4,5BRM-K14
Technical specs:

http://www.fujifilmusa.com/products/optical_devices/broadcast-hd-sd/hdtv-lenses/1-3-eng/xt17sx45-brm/

1x Canon YJ20x8,5B4 KRS SX12 (with Lens adapter ACM-17)
Technical specs:

<http://www.dsvideo.tv/images/products/925.pdf>

<u>Focus and zoom controles:</u>	3x Fujinon SRD-92B Zoom & Fujinon CFH-3 Focus Control 1x Canon ZSD-15MII Zoom & Canon FFC-15 Focus Control
<u>On-camera monitors:</u>	HD (Ruige)
<u>Fiber Connectors:</u>	3K.93C Series (Lemo)
<u>Cable length:</u>	1x 300m fibre, 4x 150 mtr. – all on electronical drums
<u>Cable Type:</u>	Hybrid Fiber (SMPTE 311) up to 300 m with full studio config Hybrid Fiber (SMPTE 311) 4x 150mtr with portable config
<u>Monitor Lines:</u>	12
<u>Displays:</u>	
<u>Waveform:</u>	1x 17" waveform monitor (Marshall) 2x LED 22" (LG)
<u>Video Matrix:</u>	Studio Video hub (Blackmagic)
<u>Multiviewers/Splitters:</u>	Atem Onboard (Echolab)
<u>Digital Glue:</u>	Open Gear Converter (Blackmagic)
<u>Controller:</u>	2x Smart Control (Blackmagic)
<u>Measurement Equipment:</u>	Waveform monitor (Marshall)

VTRs:

1x Hard disk recorder: Blackmagic HyperDeck Studio

Codec Support:

Uncompressed QuickTime, Apple ProRes 422 (HQ) QuickTime, ProRes 422 QuickTime, ProRes 422 (LT) QuickTime, ProRes 422 (Proxy) QuickTime, Avid DNxHD QuickTime, Avid DNxHD MXF

Capacity disks depends on the use of the codec.

For example SSD 512 GB:

Apple ProRes 422 (HQ) QuickTime(303 min), ProRes 422 QuickTime (436 min), ProRes 422 (LT) QuickTime (596 min), ProRes 422 (Proxy) QuickTime (995 min),Avid DNxHD MXF (337 min)

Technical Specifications:

<https://www.blackmagicdesign.com/products/hyperdeckstudio/techspecs/W-HYD-04>

1x DeckLink Studio (Blackmagic)

Audio Mixer

1x LS9 (Yamaha)

Intercom Matrix:

1x MS-704 (ClearCom)

1x RM-702 (ClearCom)

IFB System: 2x IF4W4 (ClearCom)

VW CRAFTER HD OB VAN – up to 5 cameras –ready to produce

LIST OF EQUIPMENT

1x Video Mixer Echolab Atem Ouverture 1 – 1ME

1xEcholab Remote Aux control

5x Wren electronics Cam linx Base stations

5x Wren electronics Cam linx Heads

3x Wren electronics Cam linx Audio option

1x Hybrid Fiber (SMPTE 311) cable 300 mtr.

- 4x Hybrid Fiber (SMPTE 311) cable 150 mtr.**
- 6x Skeleton drum electrically driven**
- 1x BlackMagic Studio VIDEO HUB (16in/32out)**
- 2x BlackMagic Smart Control**

- 1x BlackMagic Open Gear Converter**
- 1x BlackMagic Open Sync Generator**
- 2x BlackMagic Open SDI TO HDMI**
- 1x BlackMagic Open audio to SDI**
- 1x BlackMagic HyperDeck Studio**
- 1x PC with BlackMagic DeckLink Studio**
- 1x Marshall Waveform monitor**
- 7x LG TV 22LE5500**
- 1x LG TV 47LE5500**
- 6x Panasonic AG-EC4G**
- 5x Panasonic AG-HPX-300 series with HD lens included**
- 5x Camera flight case**
- Tripods: 3x Vinten V5AS-AP1F included**
- 1x Varizoom VZCINETRACSYSTEM**
- 1x Secced SC-V12/100AH**
- 3x Fujinon SRD-92B**
- 3x Fujinon CFH-3**
- 1x Fujinon ACM-17**
- 1x Canon YJ20x8.5B4 KRS SX12**
- 1x Canon MS-15M**
- 1x Canon FFC-15**

4x Ruige TL-S700HD

1x Power Distributor 32A

1x Level one FSW-1617

1x Clear-Com MS-702

1x Clear-Com MS-704

2xClear-Com IF4W4

2x Clear-Com GM-18 microfon

5x Clear-Com headset

1x Yamaha LS9-16

1x Millenium SP 8

1x Kramer VM-4HDMI

4x Alesis M1Active320

1x Air conditioner Coleman Mach

Wren electronics Camlinx Base stations:

The following CAMERAS CAN BE CONNECTED TO Cam Linx camera control system:

Sony cameras:

HDCAM camcorders: HDW-700A, HDW-650, HDW-750, HDW-F900/H/R XDCAM
HD422Professional Disc camcorders:PDW-680, PDW-700, PDW-F800 XDCAM HD422
Memory camcorders: PMW-300, PMW-400, PMW-500 XDCAM EX Memory camcorders:
PMW-EX3, PMW-320, PMW-350, PMW-F3 Digital Cinematography & 4K XAVC :F23, F35,
F65, PMW-F5, PMW-F55 Studio cameras: BVP-950A, BVP-750A, BVP-550/570, HDC & HXC
series

Supported Camera Recorders Panasonic P2 HD:

AG-HPX255
AG-HPX371
AG-HPX500 series
AG-HPX600 series
AJ-HPX3700

sports tv media distribution

Paradeisergasse 9 • 9020 Klagenfurt, Austria
Tel.: +43 463-90 8000 • Fax: +43 463-90 8000-99
e-mail: stvmd@stvmd.com • <http://www.stvmd.com>

AJ-HPX2700
AJ-HPX3100
AJ-HPX2100

JVC

GY-HD250/201/200 ProHD HDV camcorders
HM700 & HM790 series PROHD series camcorders.

Room Layout:

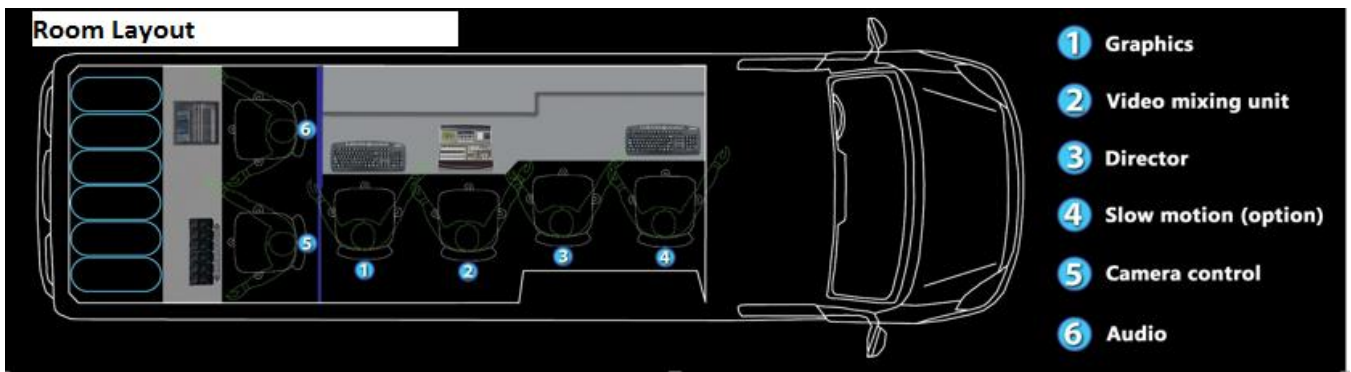



sports tv media distribution

Paradeisergasse 9 • 9020 Klagenfurt, Austria
Tel.: +43 463-90 8000 • Fax: +43 463-90 8000-99
e-mail: stvmd@stvmd.com • <http://www.stvmd.com>



Audio Area-Mixer: Yamaha LS9-16



HD OB VAN -VW Crafter - Glue Equipment

sports tv media distribution

Paradeisergasse 9 • 9020 Klagenfurt, Austria
Tel.: +43 463-90 8000 • Fax: +43 463-90 8000-99
e-mail: stvmd@stvmd.com • <http://www.stvmd.com>



HD OB VAN - up to 5 cameras

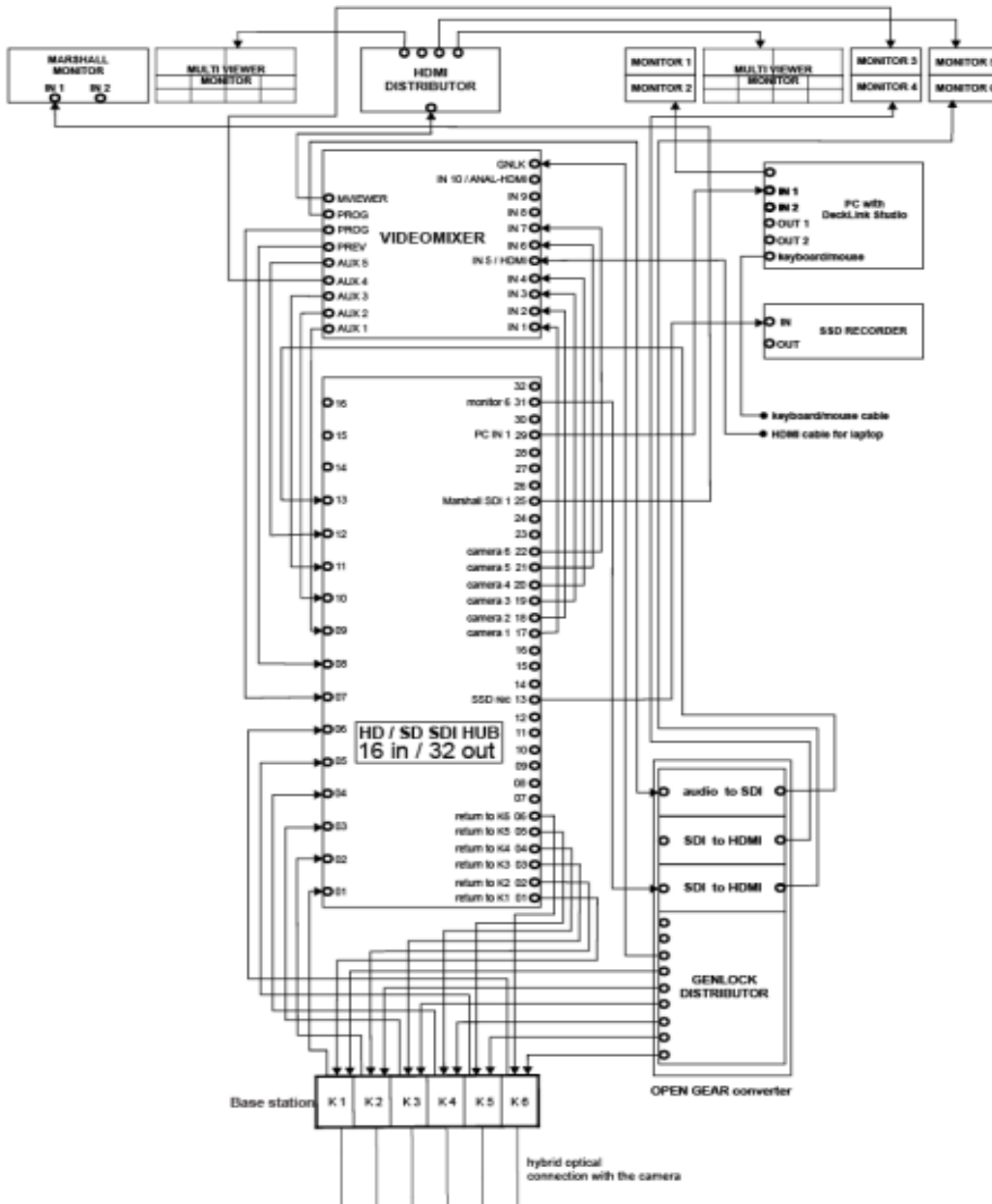

HD OB VAN - Communication

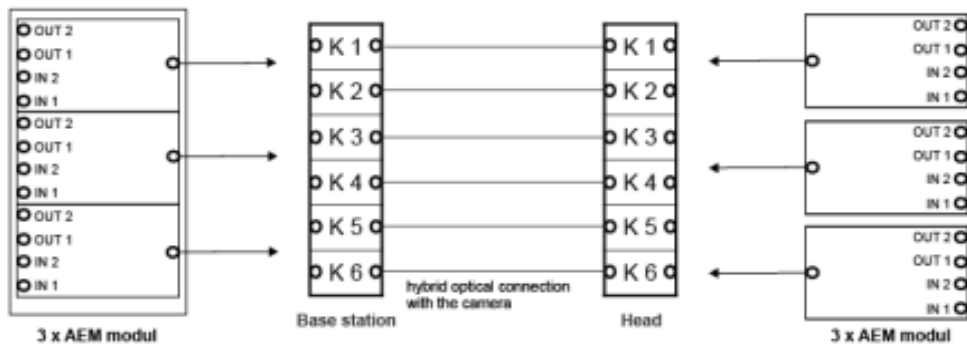
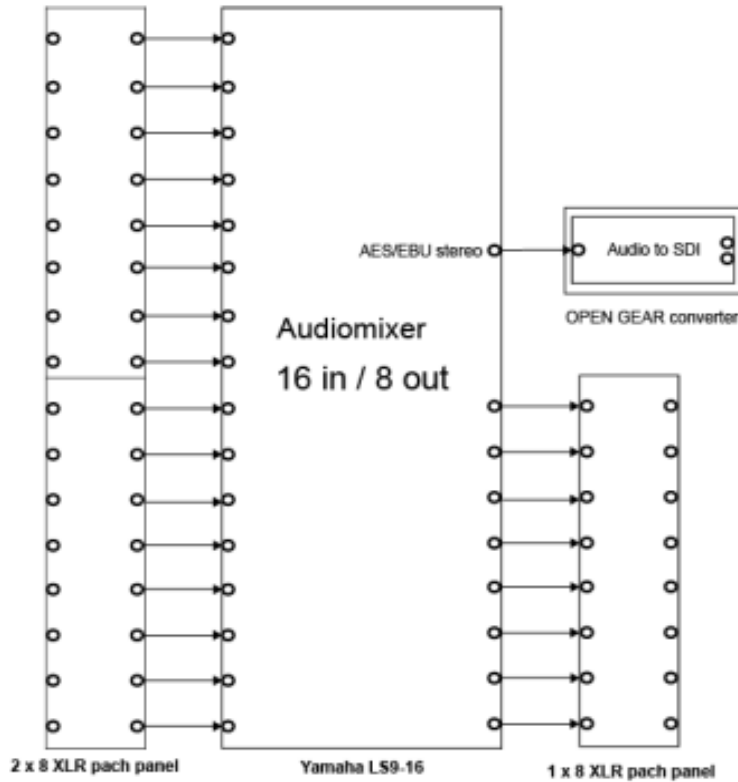

HD OB VAN - Audio

